

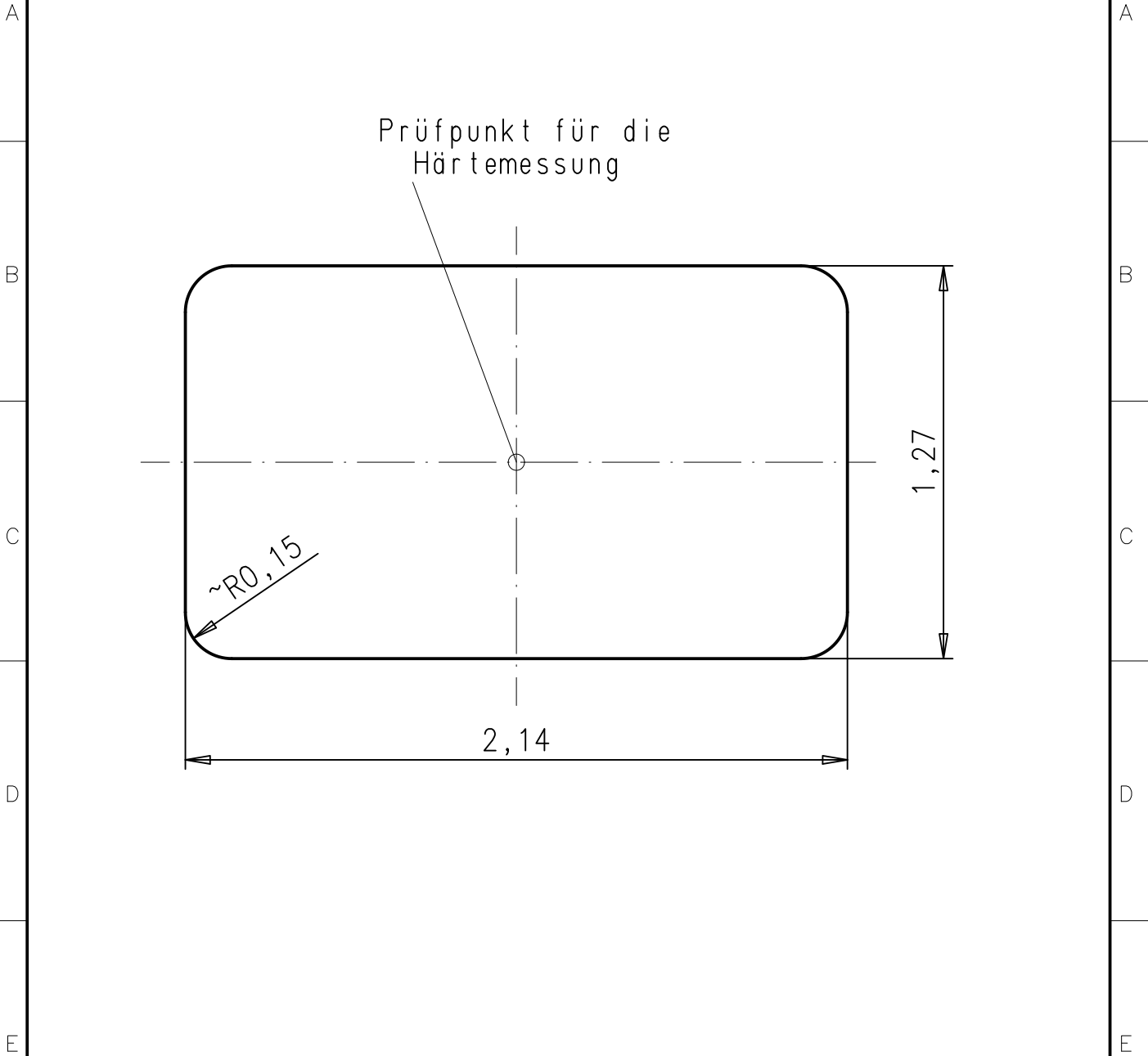

1 2 3 4



(g) (f) (e) (d) (c) (b) (a)				Freimasstoleranz:	Oberfläche:	 FERD. WAGNER Pforzheim		
				± 0,05				
				Werkstoff:				
				Datum:	Name:			
				Bearbeitet:	17.07.06	K.S.	Benennung Profil	
				Geprüft:	17.07.06	D.K.		
F	Idx	Änd.-Nr.	Datum	Name	Kundenzeichnungs-Nr.:		Artikel-Nummer/Profil-Nummer	Blatt 1/1
	Fläche: 2,70 mm ²		Maßstab 50:1		Zeichnungsnr.: 7692		7692	
	Urspr.			Ers. f.		Ers. d.		

1 2 3 4